



PROMPRYLAD
RENOVATION

PROMPRYLAD. RENOVATION

REGION AND THE CITY

AIR CONNECTION

— regular
- - seasonal



TRANSPORT CONNECTION

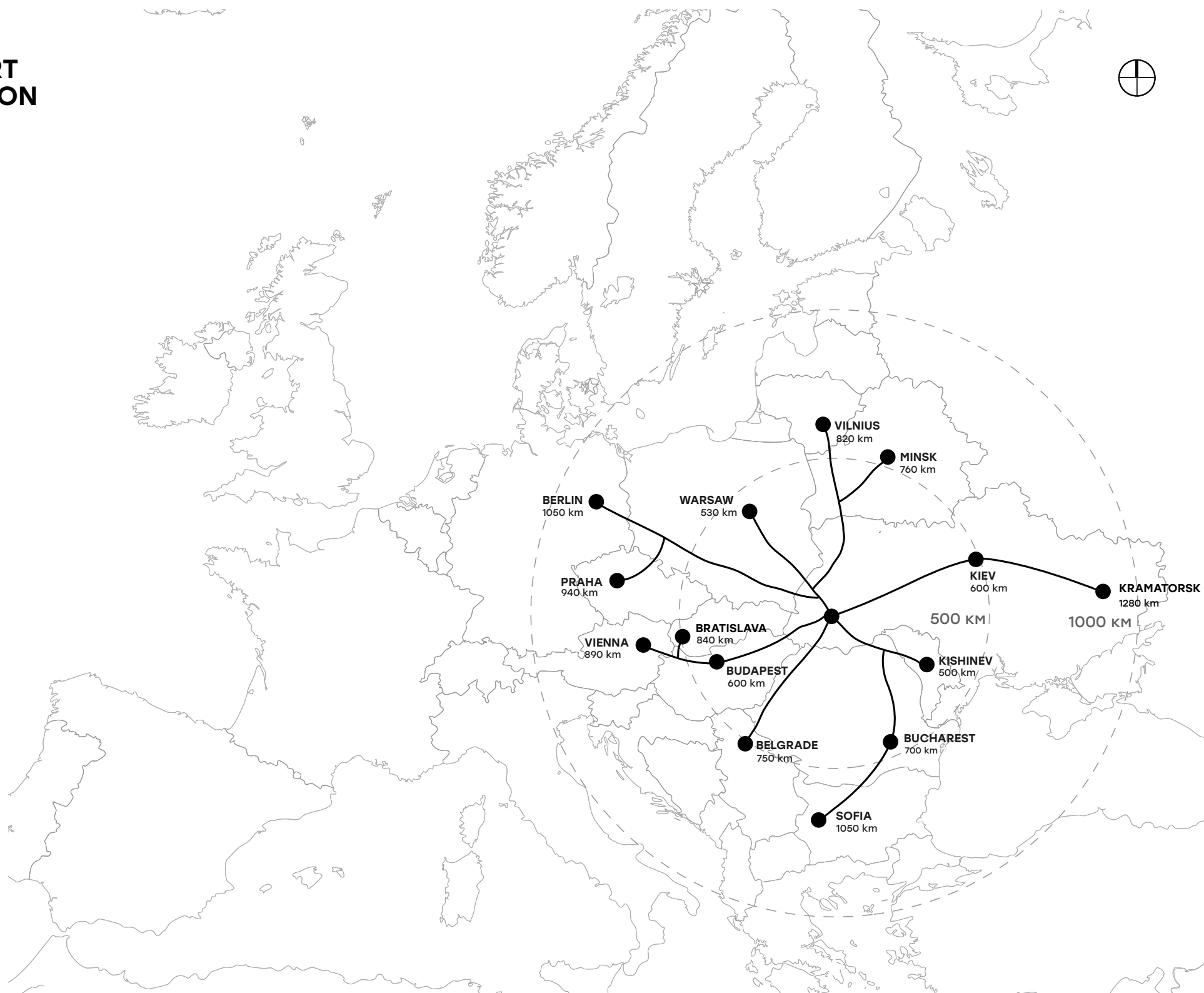

CITY

Ivano-Frankivsk is an administrative, economic and cultural center of the Ivano-Frankivsk Oblast and Ukrainian Subcarpathia. It is a city that carries the rich historical culture, ancient traditions, extraordinary artistic life and a dynamic economy.

The regional center is located in the intersection of two rivers: Bystrytsia of Nadvirna and Bystrytsia of Solotvyn. A good geographical location brings Ivano-Frankivsk closer to the EU member states and creates favorable conditions for multilateral development.

POPULATION STATISTICS: (thousands people)

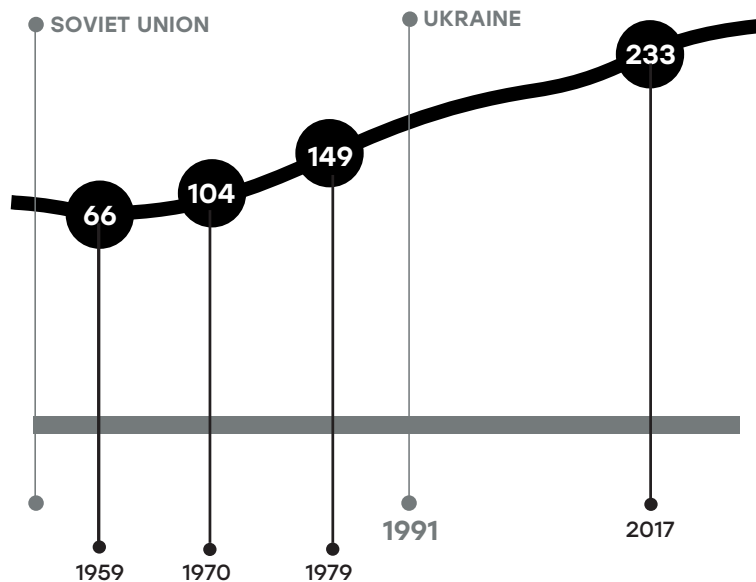

COMPRASION

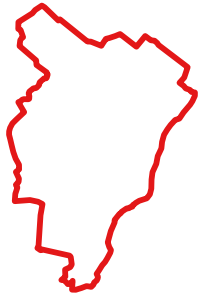

IVANO-FRANKIVSK:

Square: 83,73 km²
Population: 233 360
Founded: 1662

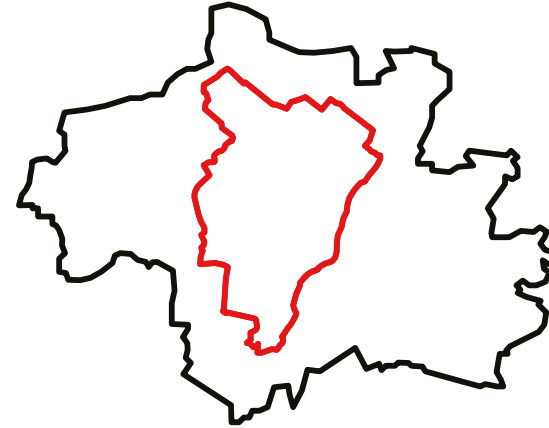

MUNICH:

Square: 310,43 km²
Population: 1 424 604
Founded: 1158

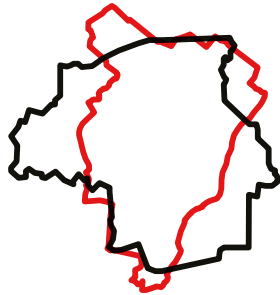

EINDHOVEN:

Square: 88,84 km²
Population: 217 228
Founded: 1232

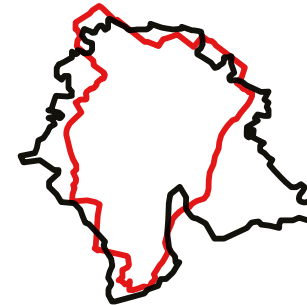

ZURICH:

Square: 91,88 km²
Population: 402 762
Founded: 929

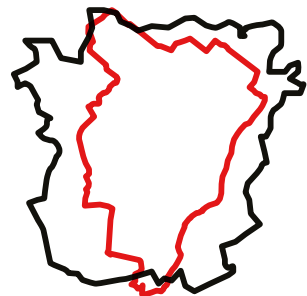

GRAZ:

Square: 127,6 km²
Population: 276 526
Founded: 1128



BASEL:

Square: 22,75 km²
Population: 165 529
Founded: 374

INDUSTRIAL HERITAGE

The city of Ivano-Frankivsk is included to the category of industrial centers, the basis of which is the machine-building, forestry, woodworking, food and light industry. But today the territory of the former industrial giants of Ivano-Frankivsk region is not associated with the industrial development and a place of work for many thousands of people. Now the majority of the territory it is empty and abandoned, besides some places with the remains of once powerful manufactures.



Avtolivmash



Pozitron



furniture plant



Skin plunt

TOTAL SALES OF INDUSTRY:

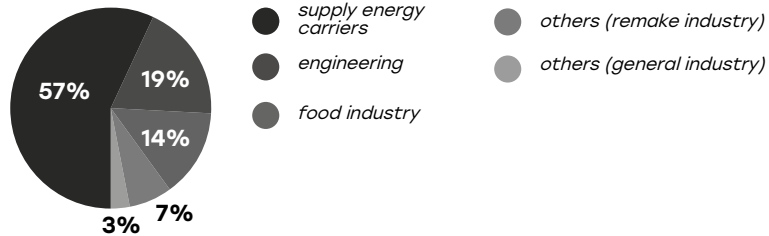

TOTAL REALIZED PRODUCTS BY INDUSTRIAL ENTERPRISES:

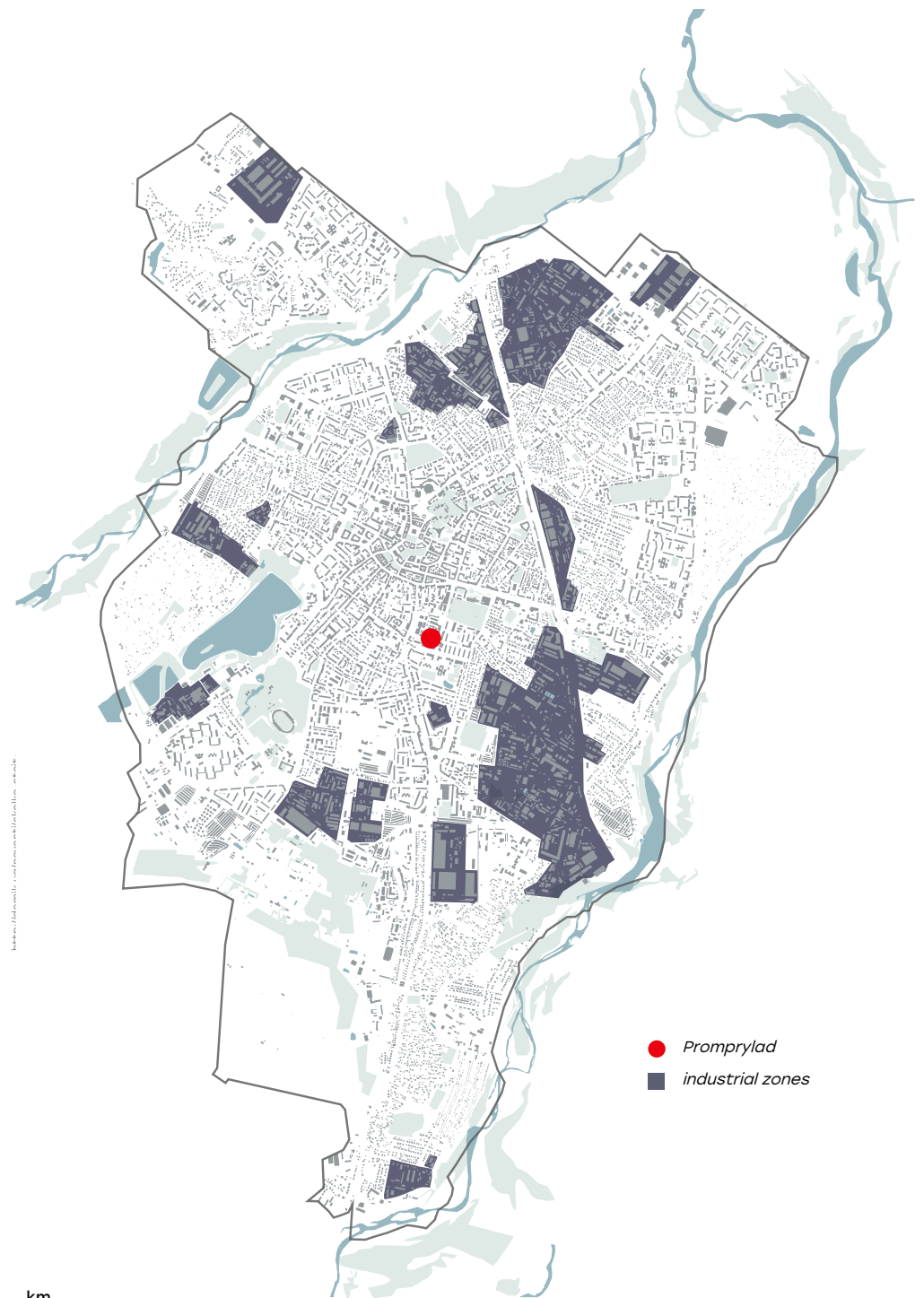
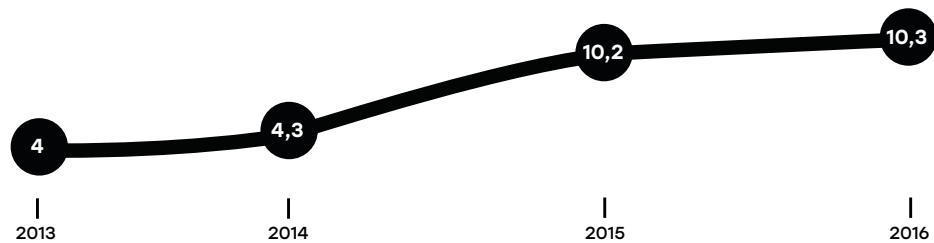

● Promprylad
■ industrial zones

PLANT

PROMPRYLAD

The history of the plant began more than 100 years ago while merging of three companies – the firm “Kraj” (1905), V. Major’s wagon-mechanical factory (1914) and the firm “Fama”(1920).

In Soviet times the plant specialized in instrument making, manufactured automatic and industrial gas counters of the rotary type. The plant produced chips for the defense industry and exported products to 68 countries of the world.

Later the plant become established as a producer of consumer goods – umbrellas, car grates, cars details, etc.

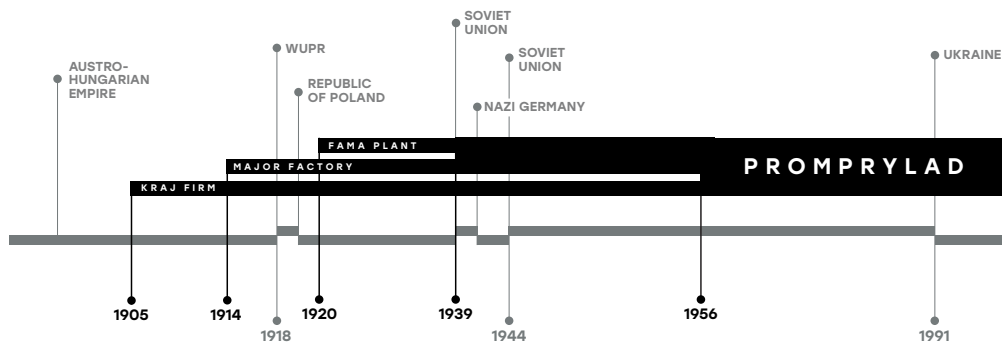

PRODUCTS EXPORT IN 80'S

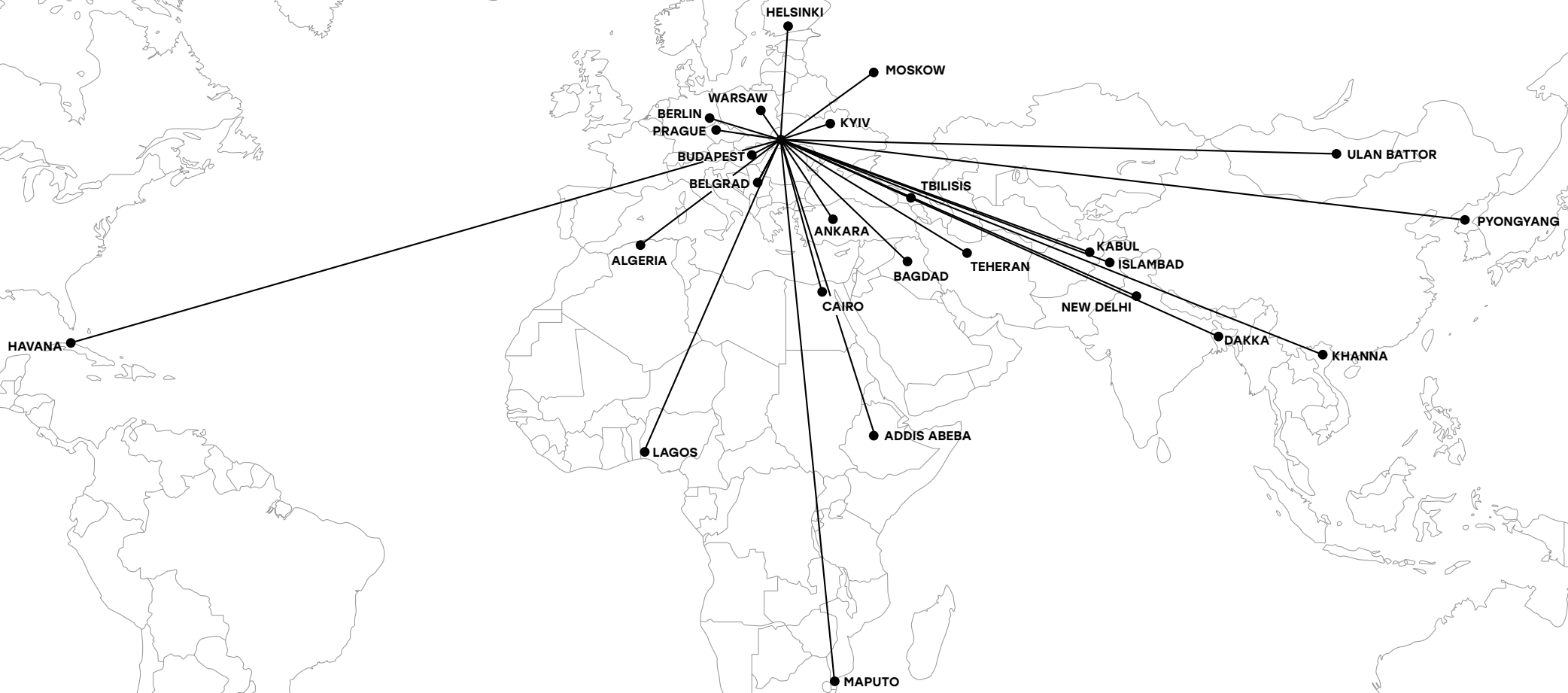

PLANT SITE NOWADAYS



ALTERNATIVE LIFE OF THE PLANT



TRANSFORMATION

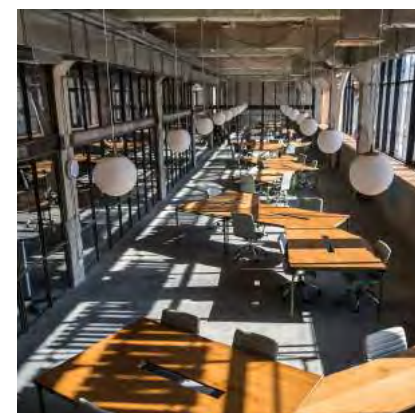

SURROUNDINGS

AVAILABILITY RADIUS

-  PROMPRYLAD
-  AIRPORT
-  BUS STATION
-  RAILWAY STATION
-  RÁTUSHA

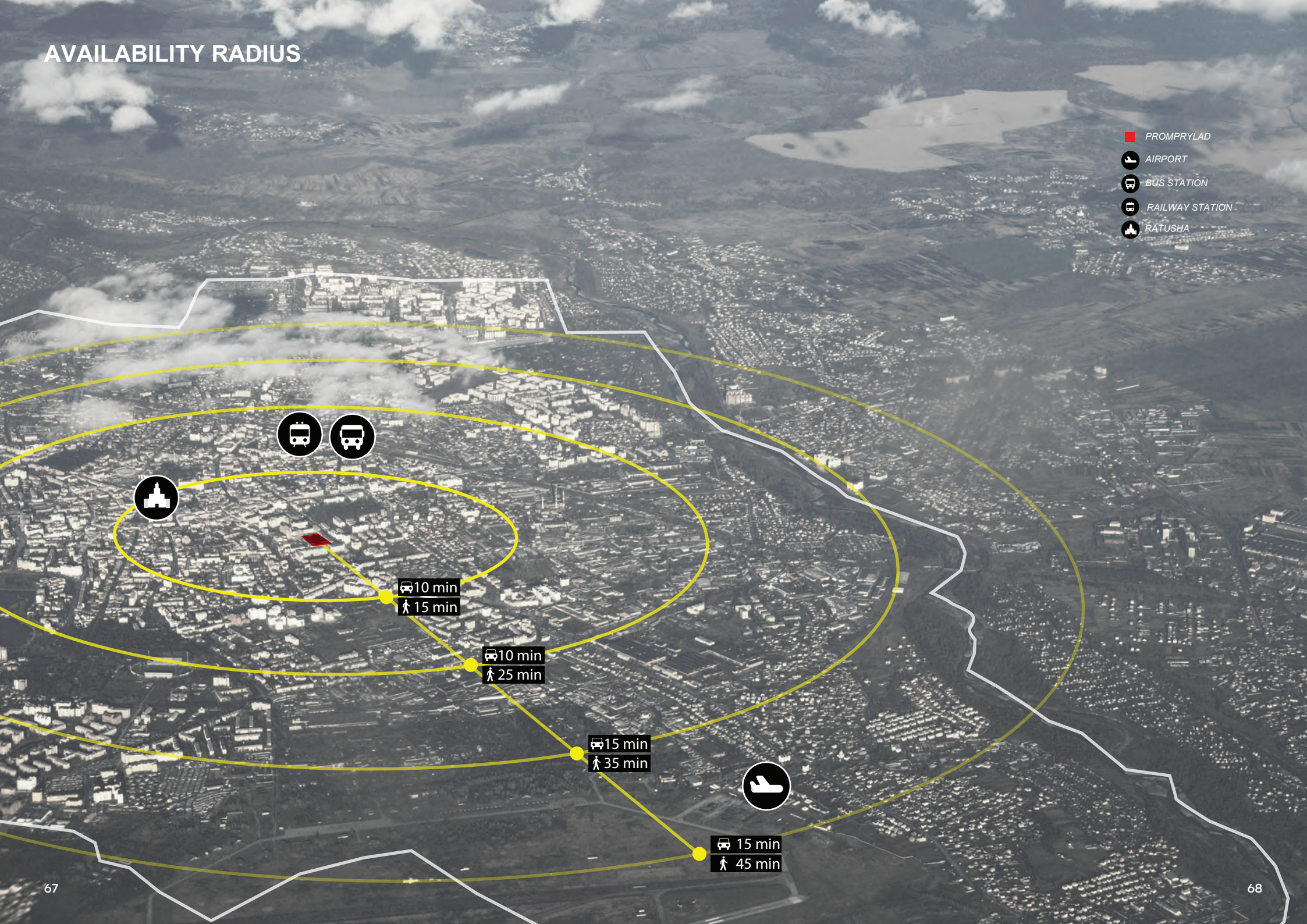

CENTER CLOSENESS

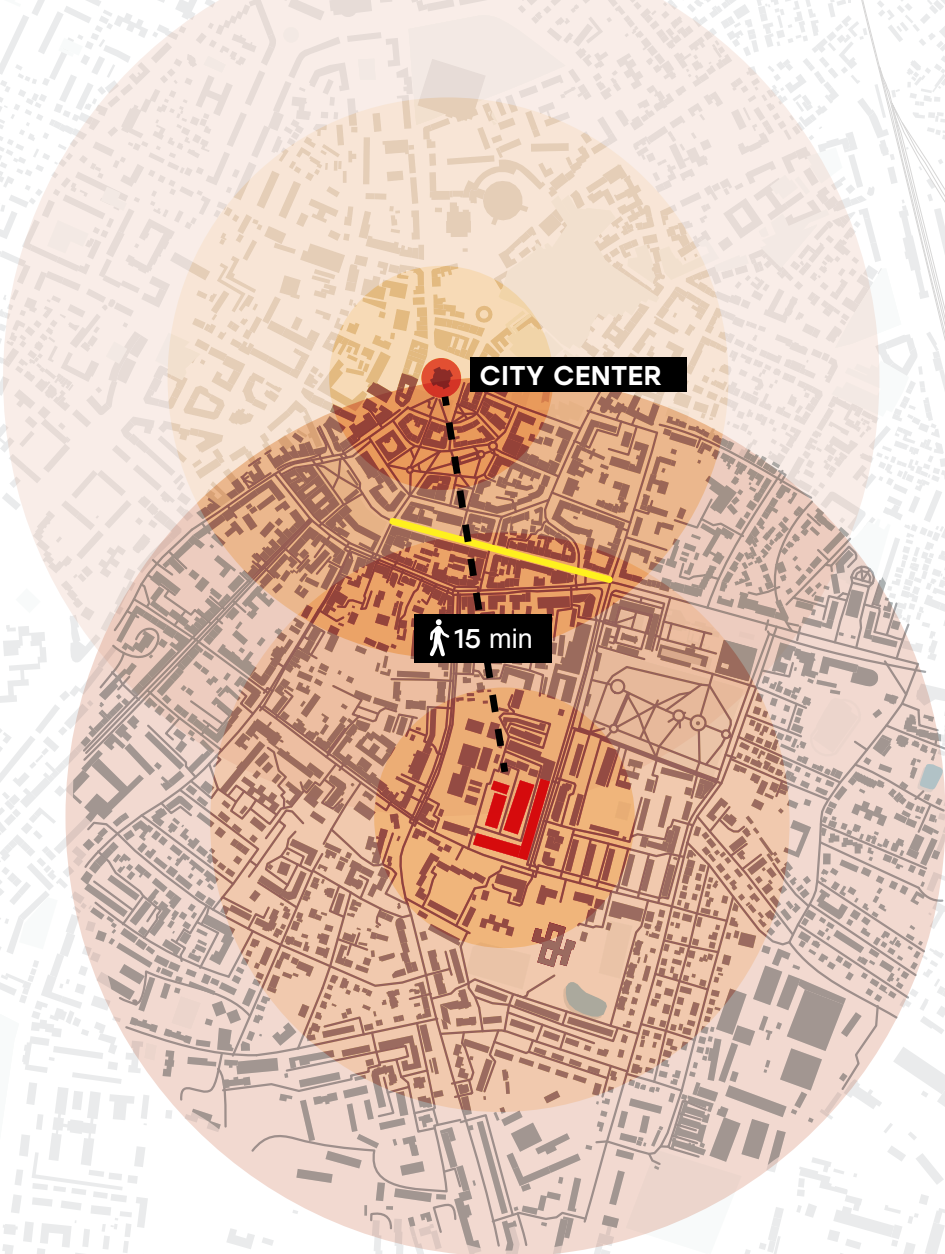

CITY CENTER

15 min

central street
"Stometriivka"



ATTRACTIVE INFRASTRUCTURE

HOTELS, HOSTELS AND APPARTMENTS

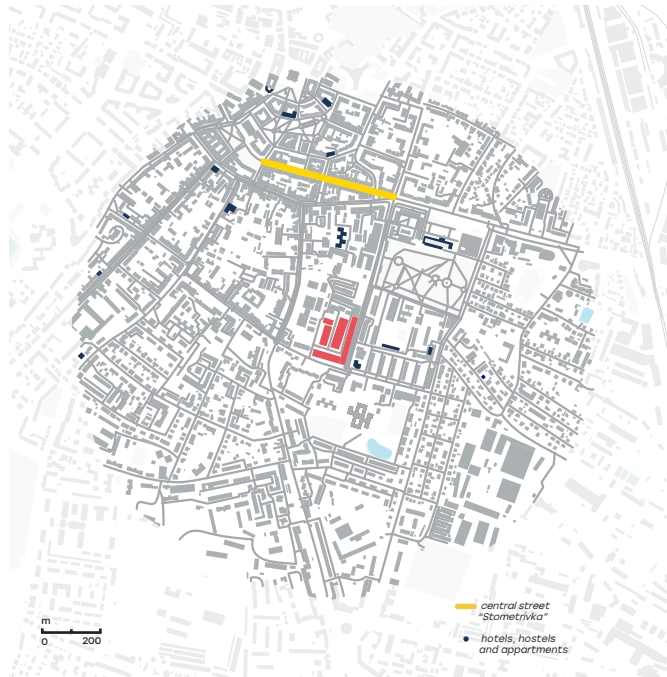

PUBLIC TRANSPORT AND CAR PARKINGS

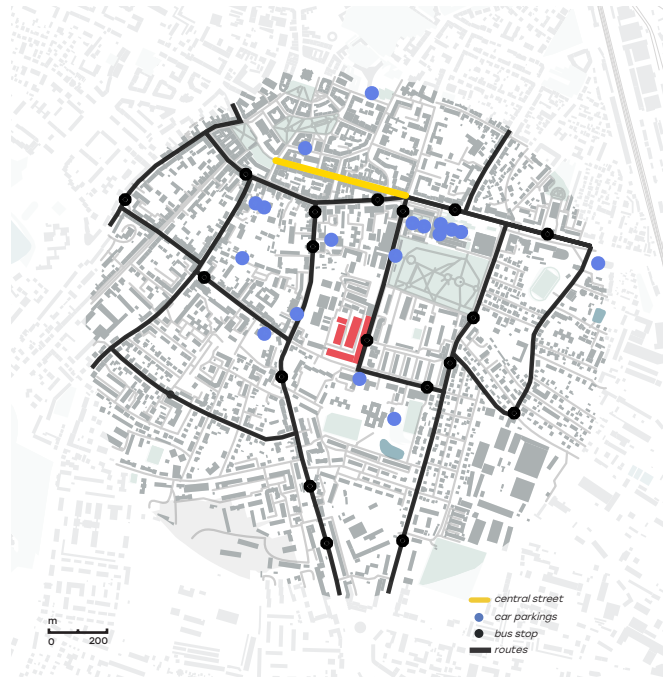

BICYCLE INFRASTRUCTURE



INFRASTRUCTURE FOR LIVING

RECREATION



EDUCATION

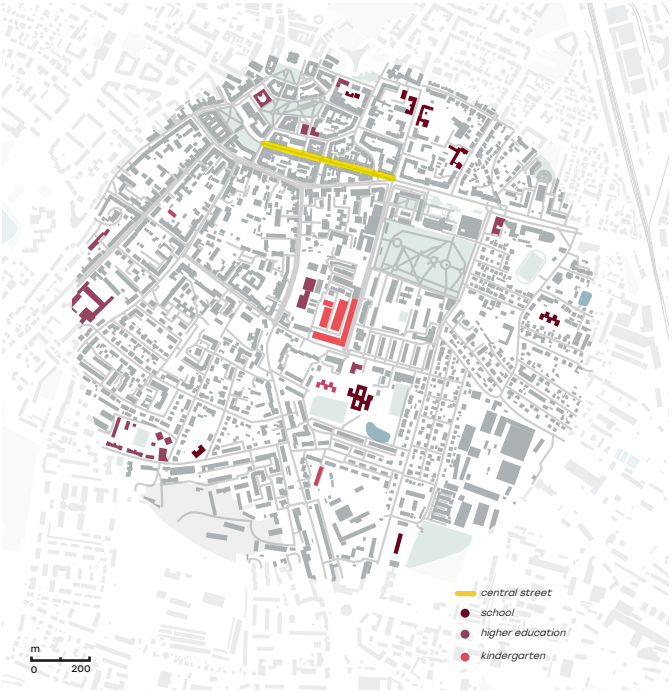

IDEA

The image features a dark blue background with several diagonal, rounded red bars of varying lengths and positions. The word "IDEA" is written in a bold, white, sans-serif font, positioned on the left side of the image, partially overlapping one of the red bars.

INNOVATION CENTER

Promprylad.Renovation is an innovation center on base of revitalized plant in Ivano-Frankivsk, Ukraine, focusing on four areas of regional development: new economy, urbanism, contemporary art and education.

Project aims to realize city and region economic potential, develop local entrepreneurship and create a model for other cities.



INNOVATION CENTER

Over the next five years, project will attract more than 700 million hryvnias of impact investments from private investors and organizations to phase-in six buildings and park.

There will be office space, laboratories, workshops, exhibition and entertainment centers, hotel and hostel, farm market, restaurants. In addition, a third part of the area will be provided under reduced rent to cultural and social initiatives, which coincide with project vision.

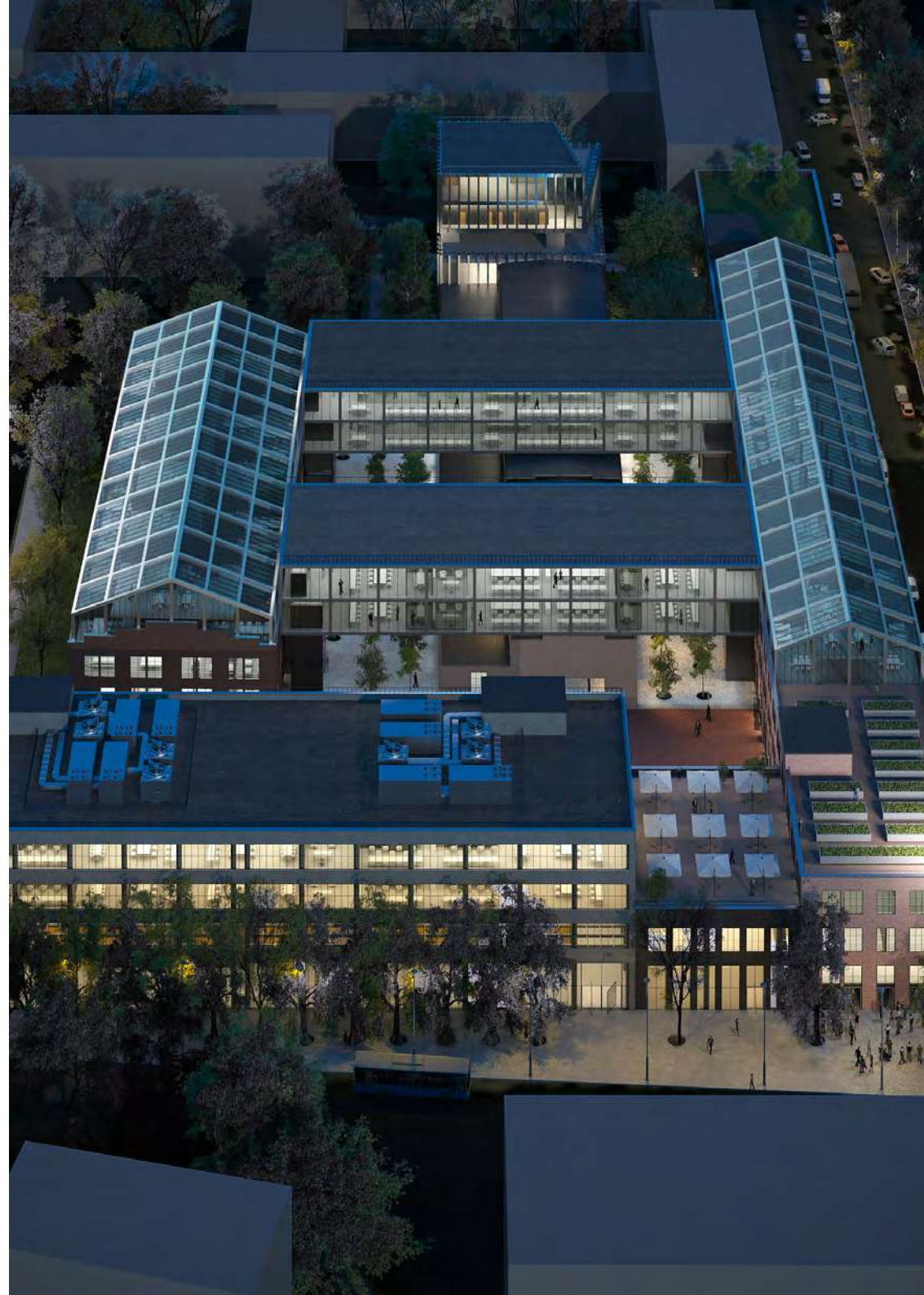

AREAS OF REGIONAL DEVELOPMENT

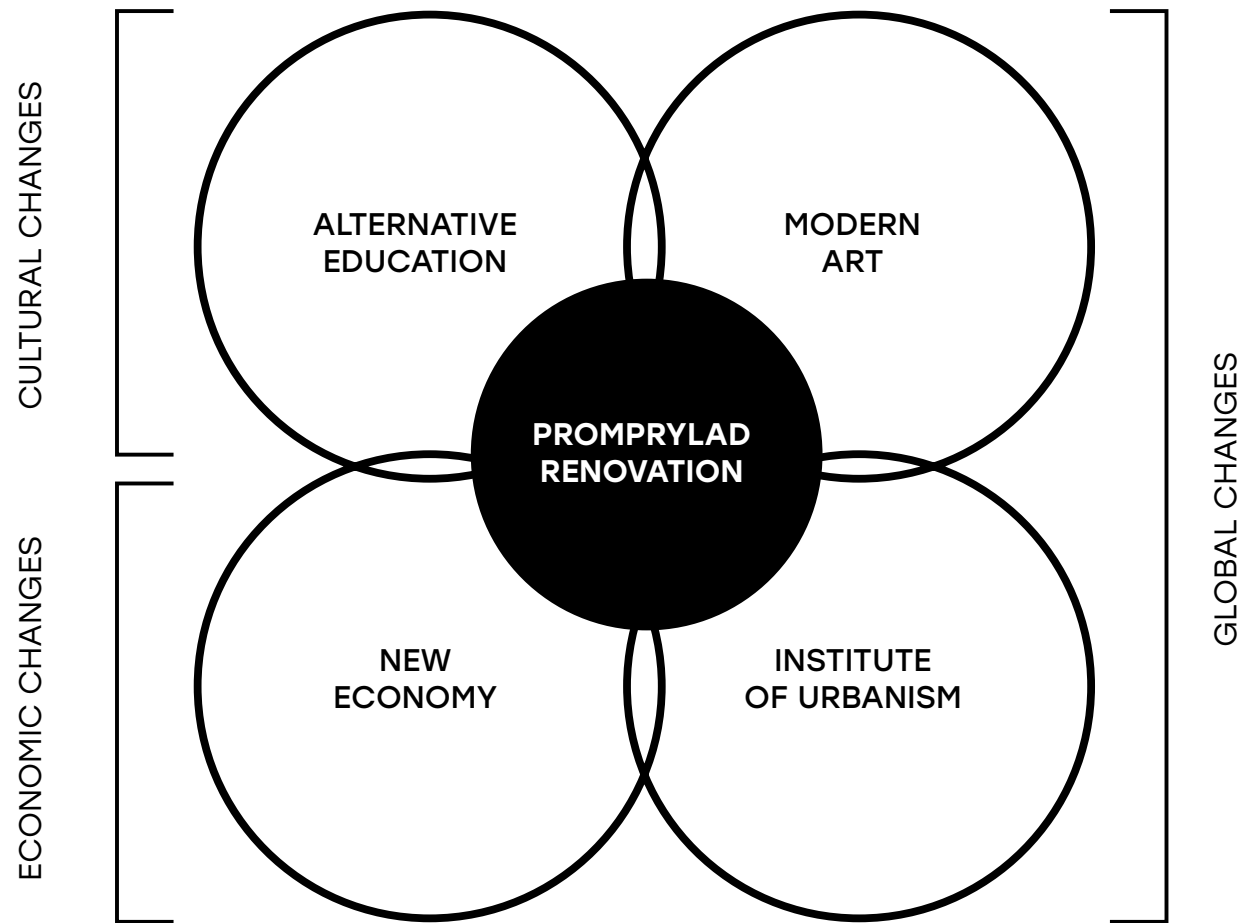

*According to SRI International study of region and Promprylad made in 2016 in Ivano-Frankivsk

CLUSTERS

AGRICULTURE AND FARMING	WOOD MANUFACTURE	GREEN ENERGY
FOOD AND RESTAURANTS	DESIGN	FILM INDUSTRY AND ANIMATION
IT	...	

* According to SRI International study of region and Promprylad made in 2016 in Ivano-Frankivsk

POSSIBLE FUNCTIONS

INFORMAL EDUCATION	IT ACADEMY FAB LAB CHILDREN CENTER CONFERENCE HALL	SERVICE
CONTEMPORARY ART	ART CENTER CONCERT HALL RESIDENCES CINEMA CENTER	CRAFT- MANUFACTURERS CAFE RESTAURANTS HOSTEL HOTEL SPORTS CENTER CYCLING HUB PARKS
NEW ECONOMY	IT CLUSTER SOCIAL BUSINESS INCUBATOR FOODHUB FARM MARKET SMALL WORKSHOPS	
INSTITUTE OF URBANISM	WORKSHOPS OFFICE OF CITY CHANGE LECTURE ROOMS SCHOOL OF OBJECT DESIGN	

AREA DISTRIBUTION

37800 M²
TOTAL AREA

1/3
SUBSIDIARY
RENT AREA

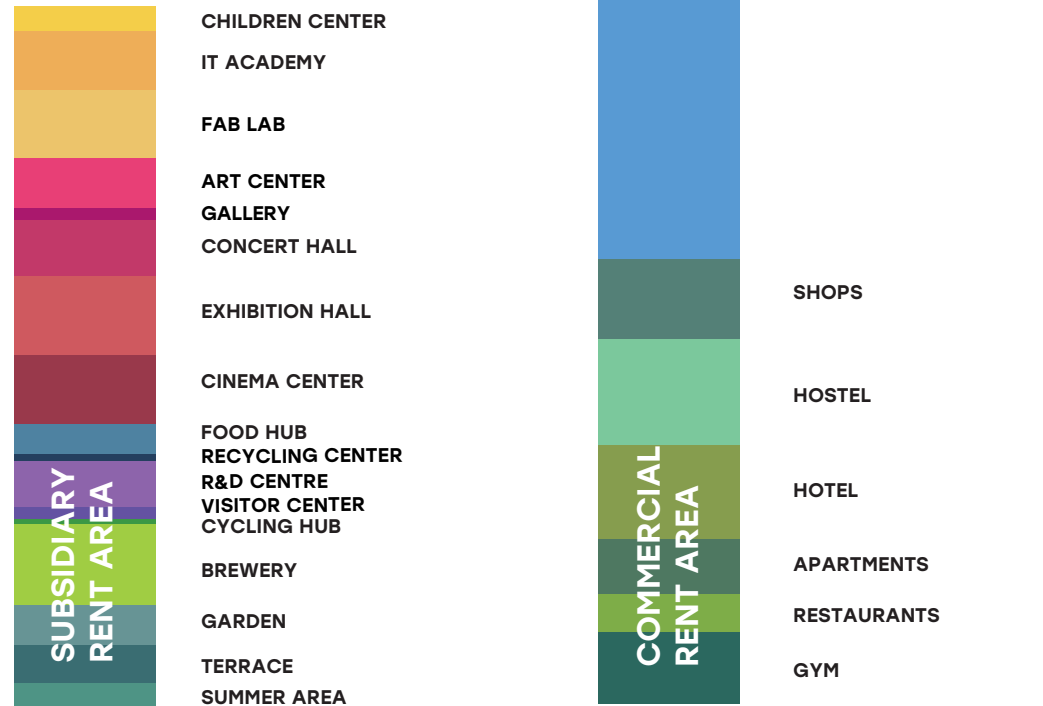

IMPACT INVESTMENT

Promprylad.Renovation is an *impact investment project where investor receives a return on investment as a profit from dividends and a social impact on regional development.



**\$228 billion – reported size of the impact investing market according to Annual Impact Investor Survey 2018 by GIIN*

INVESTMENT MODEL

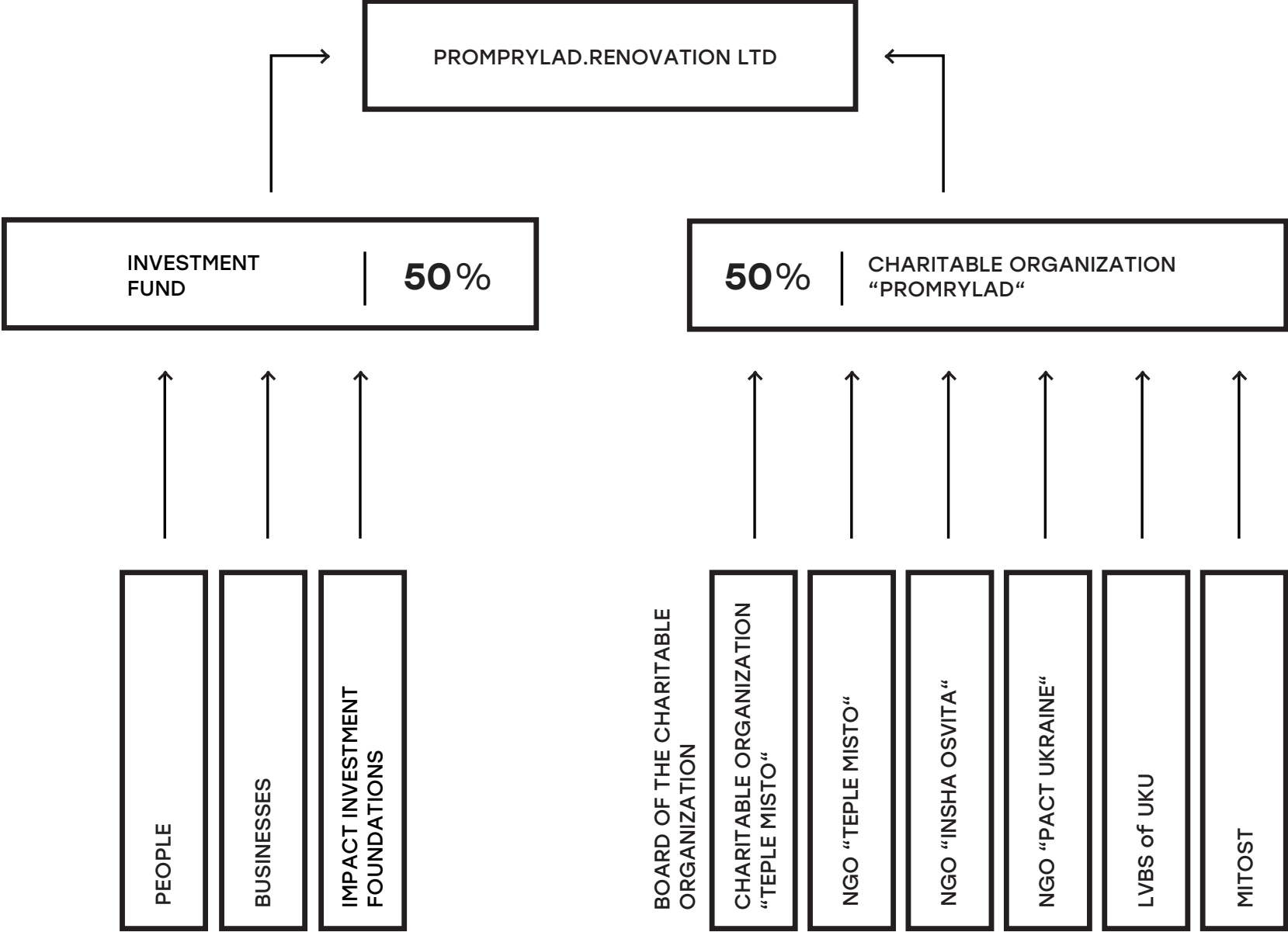

PARTNERS

Strategic partners

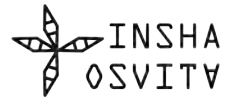

Partners of the project



RECEIVED INVESTMENTS

Institutions:

NGO "Teple Misto"	\$180 204
NGO "Insha Osvita"	\$62 832
NGO "MitOst"	\$59 887
NGO "Garage Gang"	\$3 733
IF "Renaissance"	\$86 882
LTD "23 Restourants"	\$10 000
PC "Ivano-Frankivskcement"	\$10 300
Impact Hub Odesa	\$5 000
NGO "CANactions"	\$20 225
PACT	\$18 000
SIDA (Sweden)	\$215 744
TOTAL	\$683 223

Private investors:

Yuriy Fylyuk	\$450 000
Oleksandr Buben	\$39 000
Olga Diatel	\$20 000
Andriy Chernikov	\$20 000
Dmytro Lider	\$10 000
Anastasiya Solyanyk	\$500
Kateryna Kotenko	\$500
Olexandr Bogorodov	\$500
Taras Tsyupa	\$335
Valeriya Verveda	\$500
Ivan Vitenko	\$3 236
Ira Avetisyan	\$14 350
Kateryna Prokopenko	\$2 186
Oleksandr Levytskyk	\$1 318
Liubov Shlapay	\$618
Victor Soroka	\$17 670
Yarema Stecyk	\$1 891
Tetiana Yatsyuk	\$1 085
Victor Sarapin	\$11 538
Sergiy Motovylets	\$1 149
Ievgenia Kartushova	\$500
TOTAL	\$596 376

\$ 1 279 599

PLAN OF PROJECT DEVELOPMENT

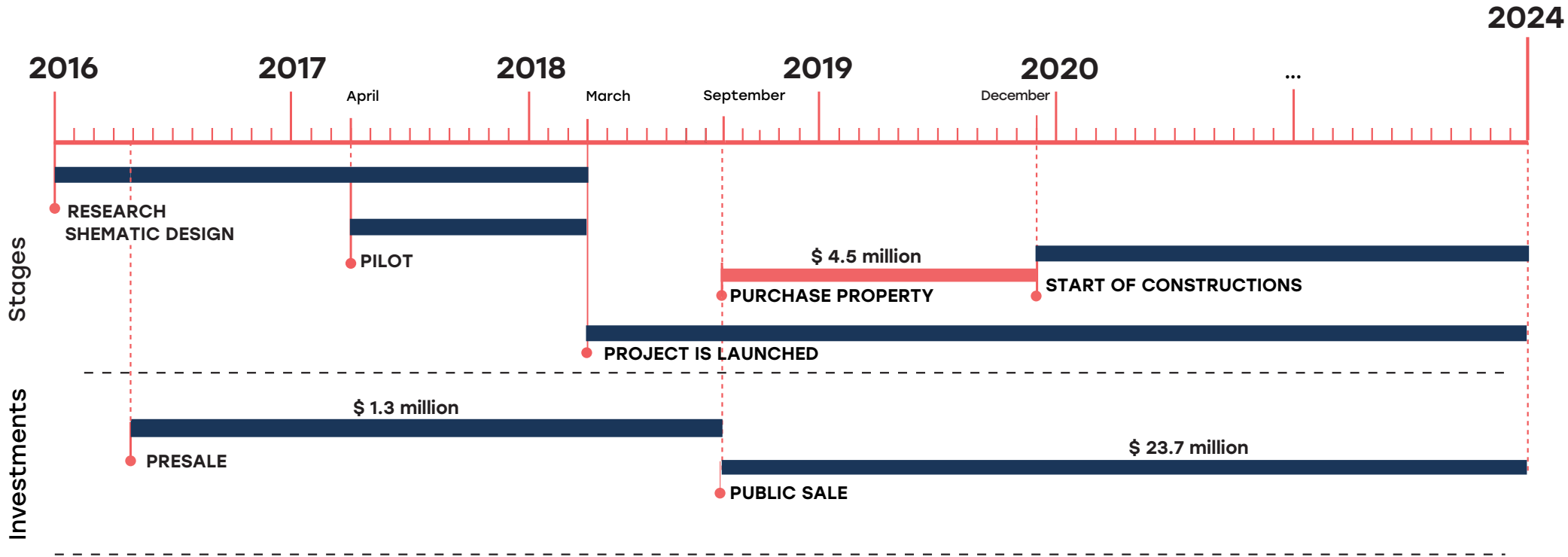

PILOT PROJECT

PILOT FLOOR

In March 2018, team rented one of the plant floors with an area of 1,789 square meters and has already launched a pilot innovation center there.

Here they united 16 spaces among them urban and multimedia labs, children educational spaces, city investment office, coworking, offices, bar, dance studio and barber school.

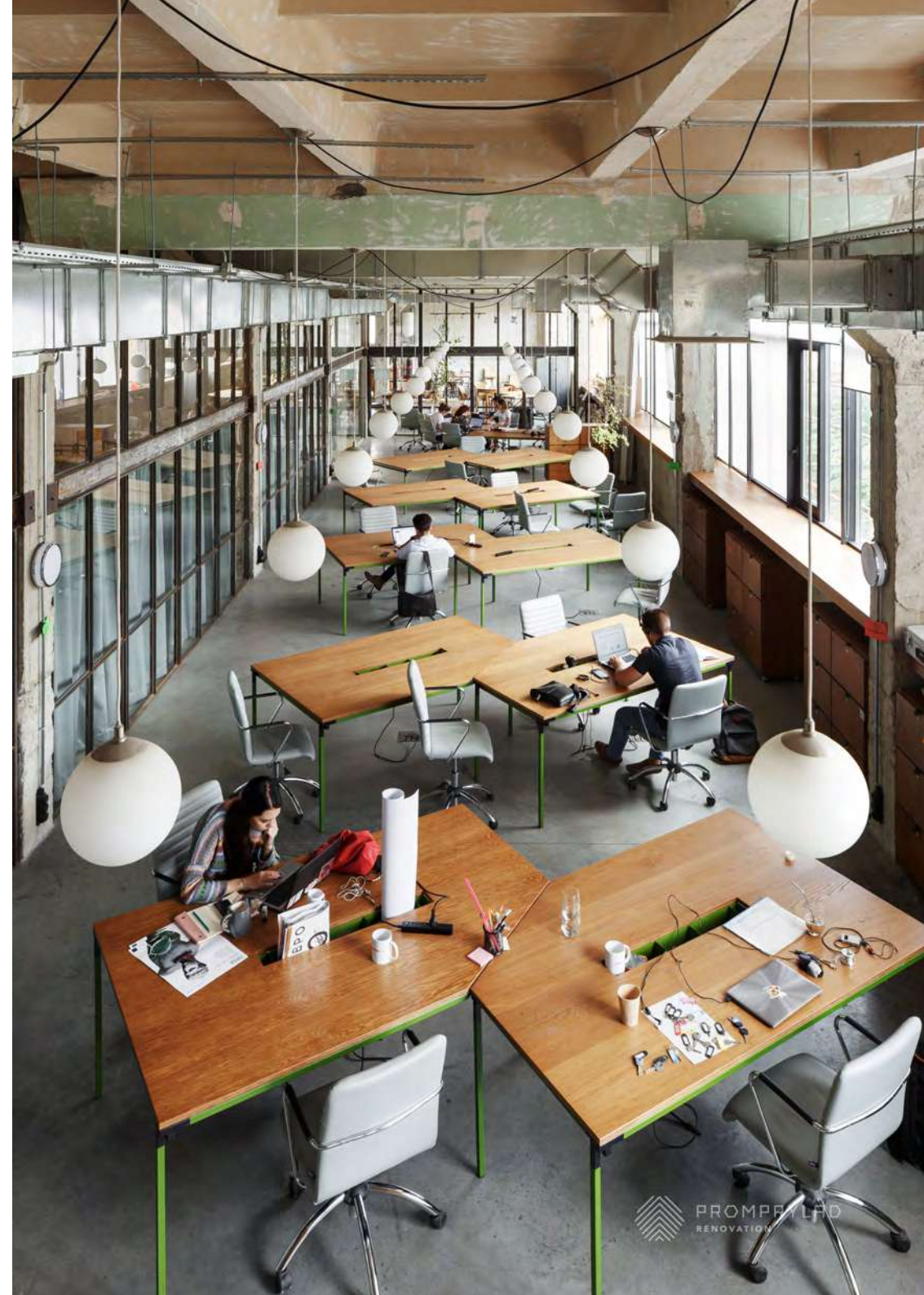

PILOT FLOOR

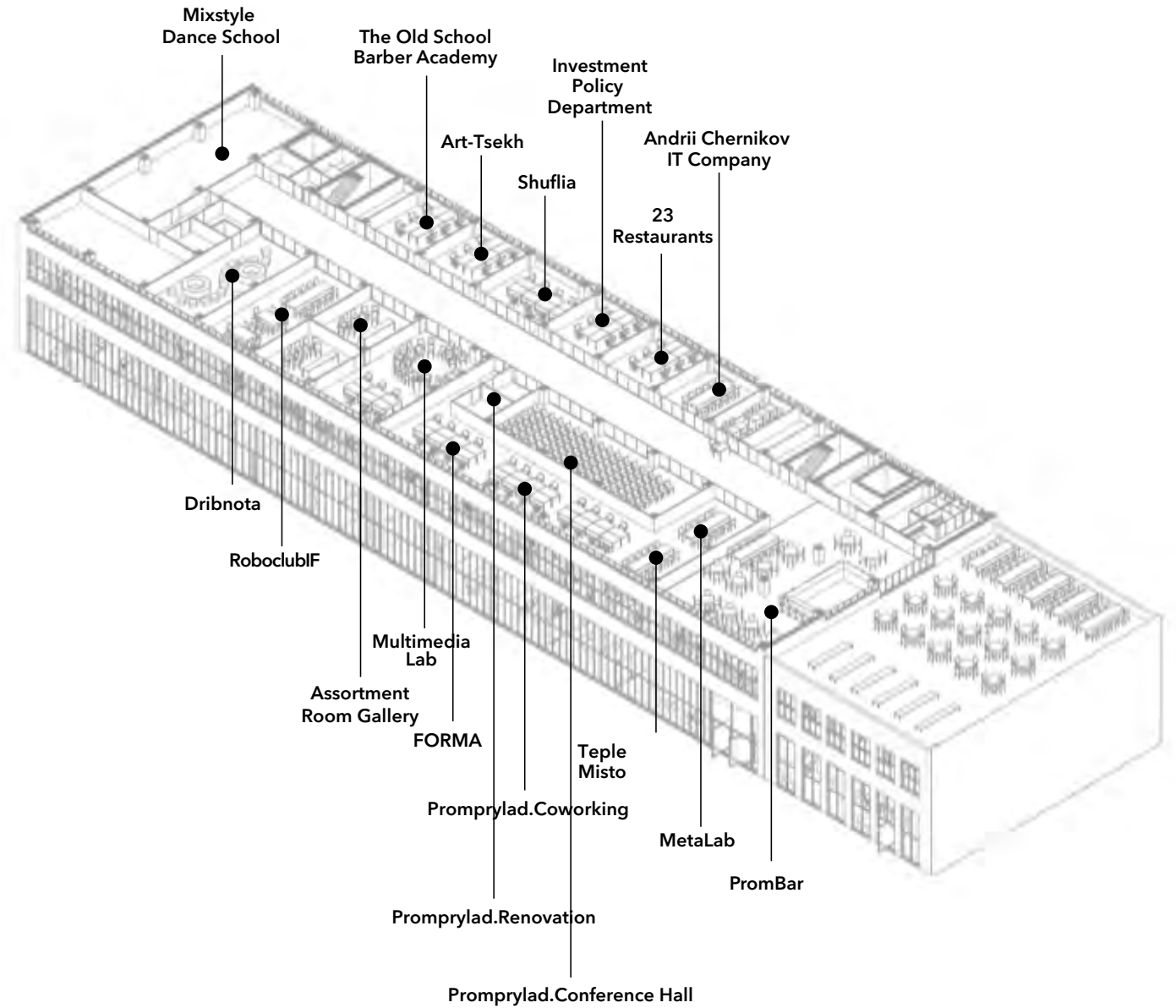

16
SPACES

1 789 M²
RECONSTRUCTED AREA

9 MONTHS
RECONSTRUCTION FINISHED IN

REALISATION



REALISATION



REALISATION



REALISATION



REALISATION

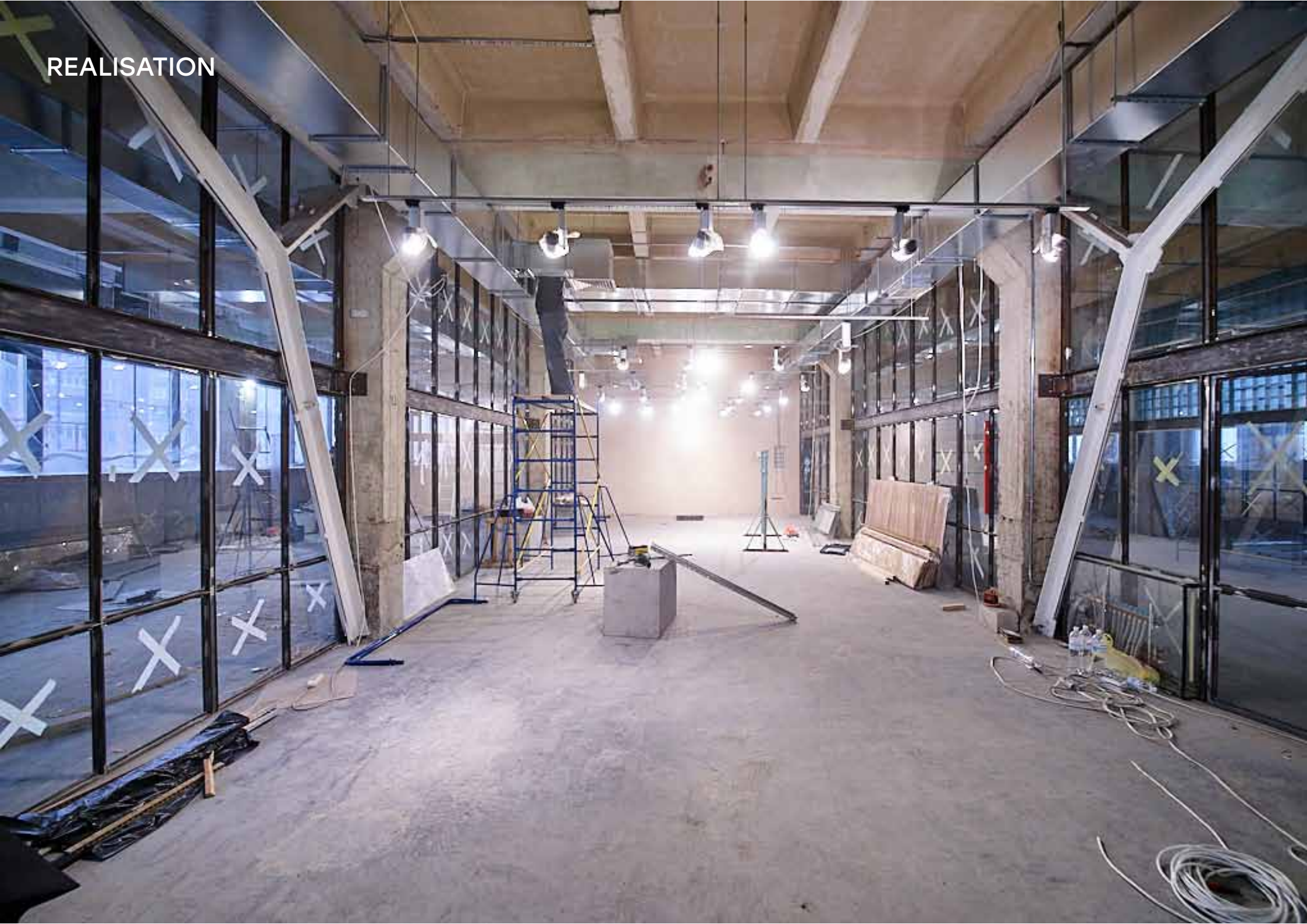





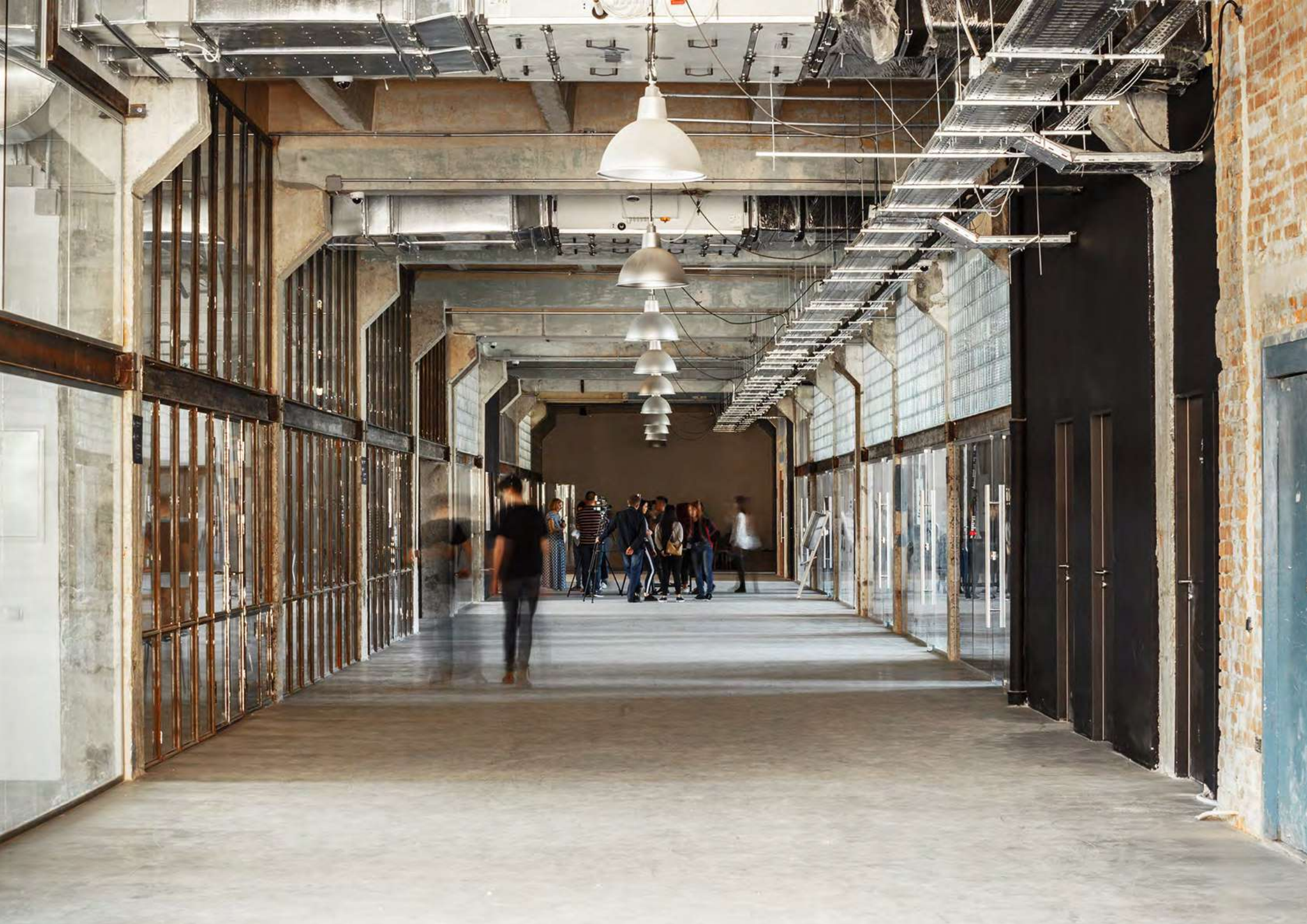

РОЗВИТОК АРХІТЕКТУРНИХ
КОНКУРСІВ В УКРАЇНІ

Caroline D'Amico



BUILDINGS

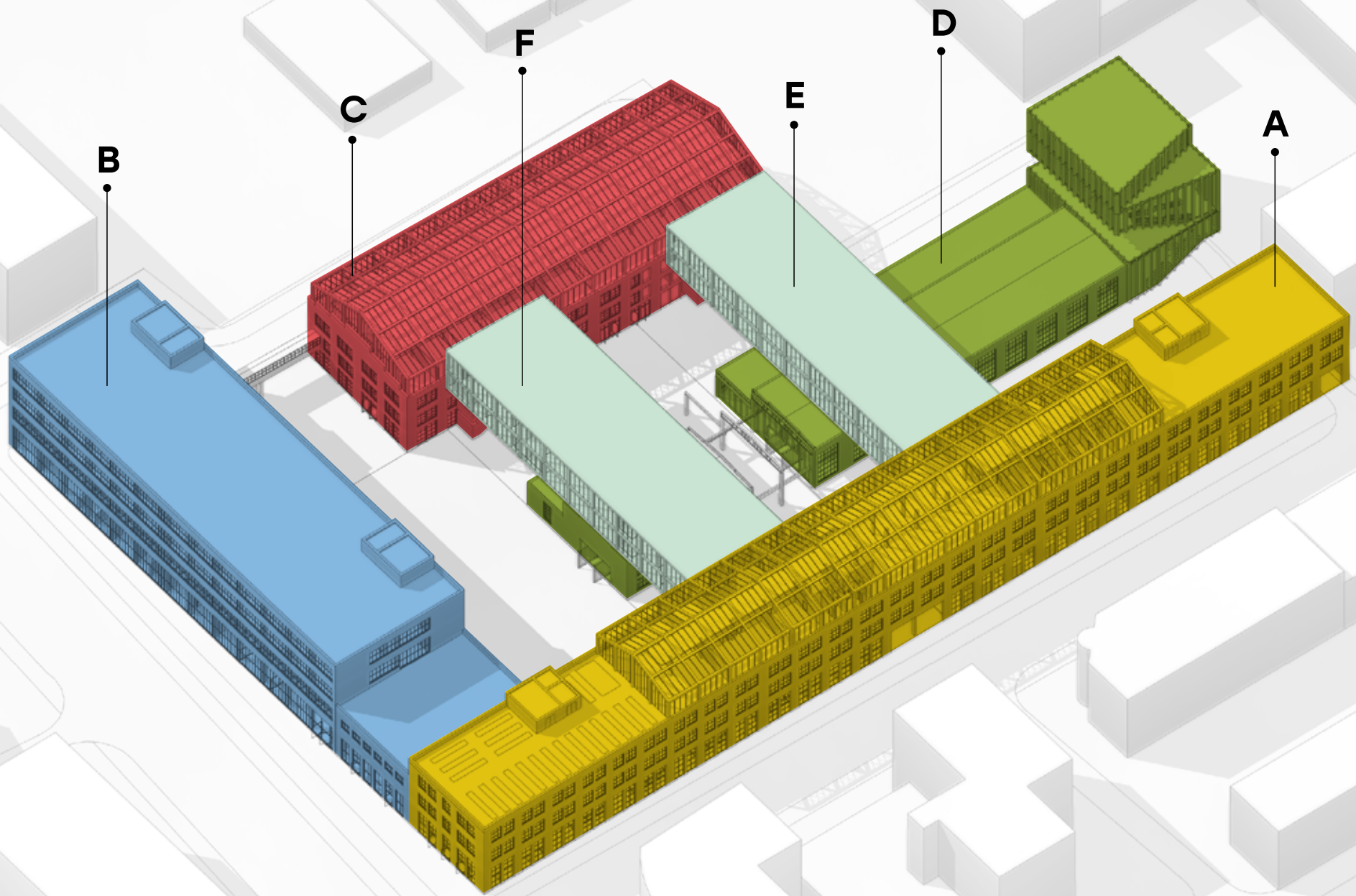

ESTIMATED BUDGET STAGES

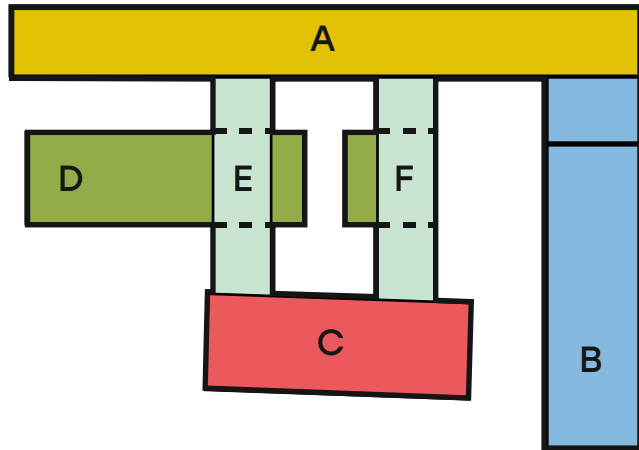

(the cost of repairs is approximate and can not be accepted as final)

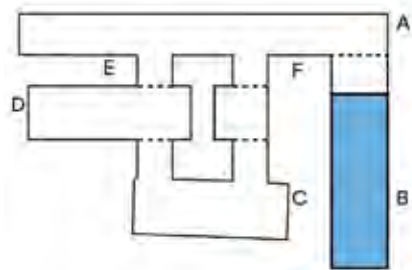

1 BILDING B
 Start - 01.01.2020
 Finish - 1.09.2020
 Approximate cost of 1 m² repair works - \$ 400

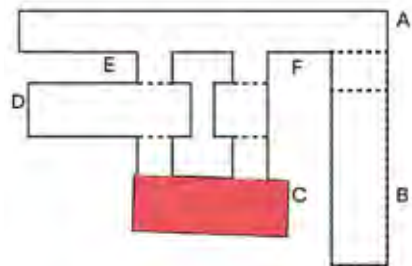

2 BILDING C
 Start - 01.01.2020
 Finish - 01.02.2021
 Approximate cost of 1 m² repair works - \$ 600

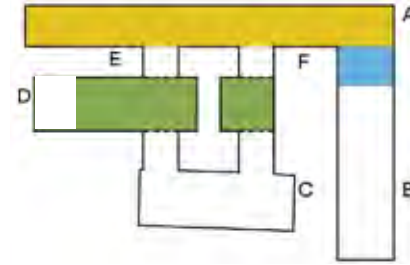

3 BILDING A/B/D (partially)
 Start - 01.01.2020
 Finish - 01.12.2021
 Approximate cost 1 m² repair works:
 bilding A - 800 \$
 bilding B - 400 \$
 bilding D - 300 \$

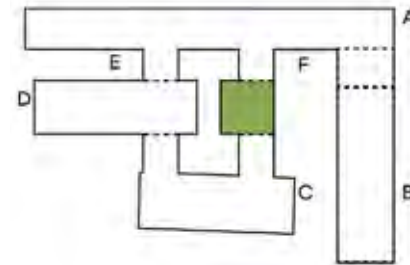

4 BILDING D
 Start - 01.01.2020
 Finish - 01.12.2021
 Approximate cost of 1 m² repair works - 700 \$

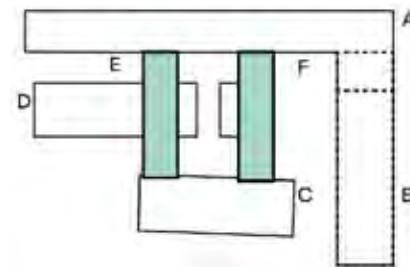

5 BILDING E/F
 Start - 01.01.2022
 Finish - 01.02.2024
 Approximate cost of 1 m² repair works - \$ 1200

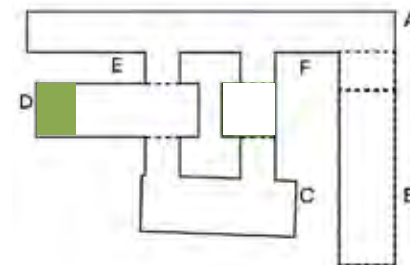

6 BILDING D
 Start - 01.01.2020
 Finish - 01.12.2021
 Approximate cost of 1m2 repair works - 1200 \$

REALISATION STAGES

1

EXISTING
BUILDINGS

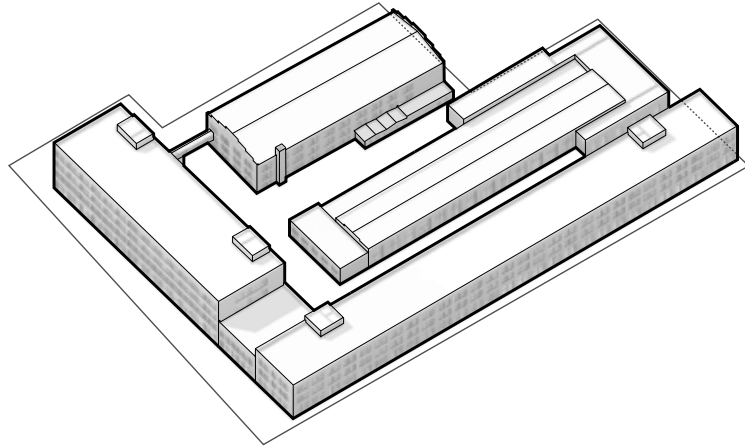

2

DISMANTLING

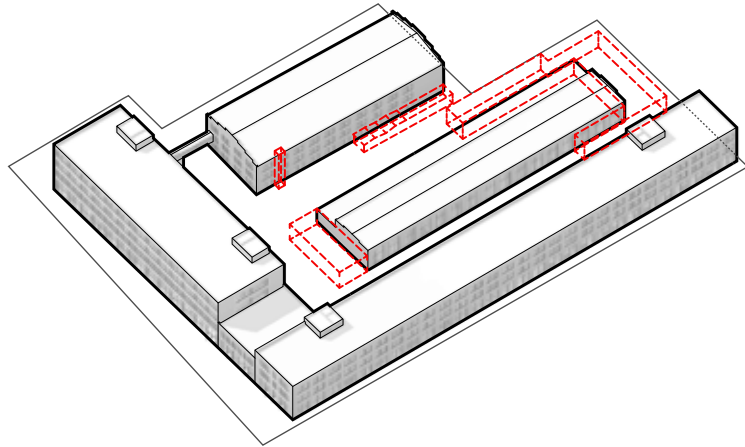

3

PORTAL
CREATION

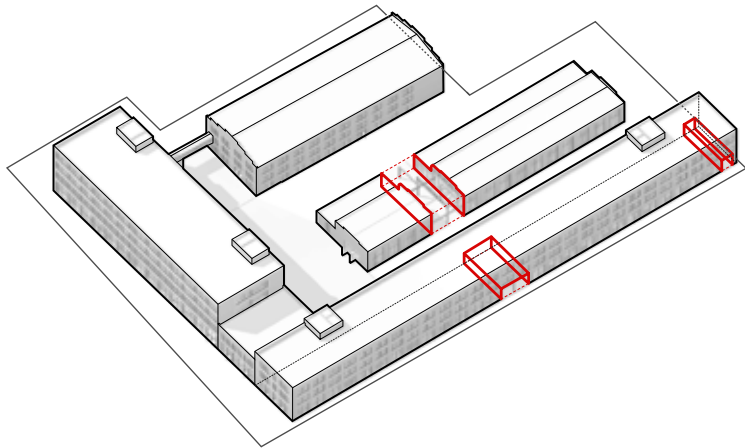

4

CREATION
MANSARDS
AND COMMUNICATON
CORE'S

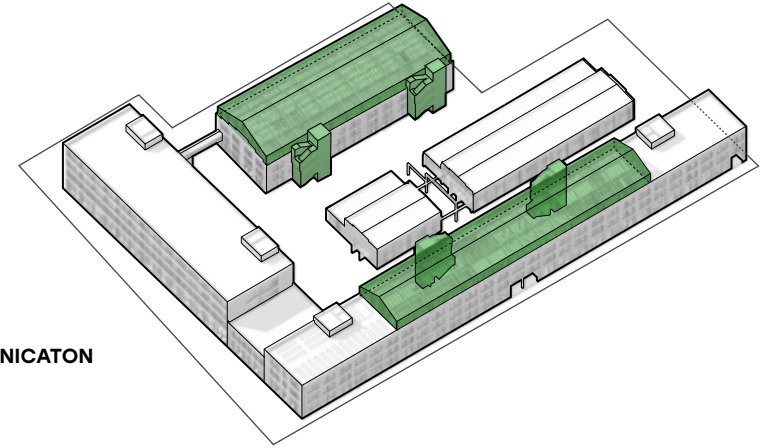

5

CREATION
OFFICE BLOCKS

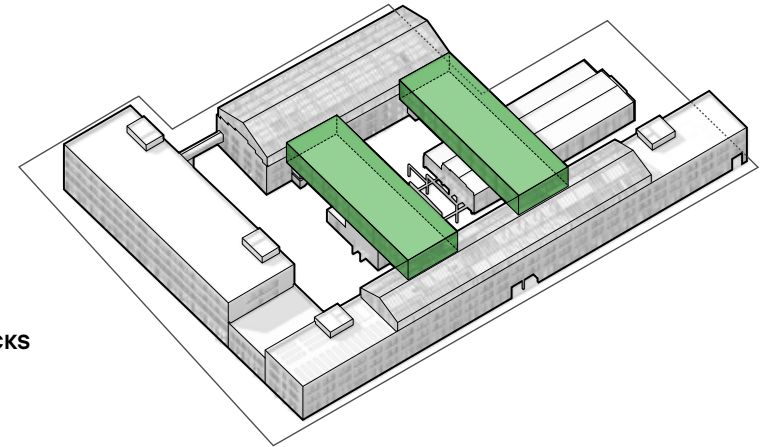

6

CREATION
CINEMA CENTRE

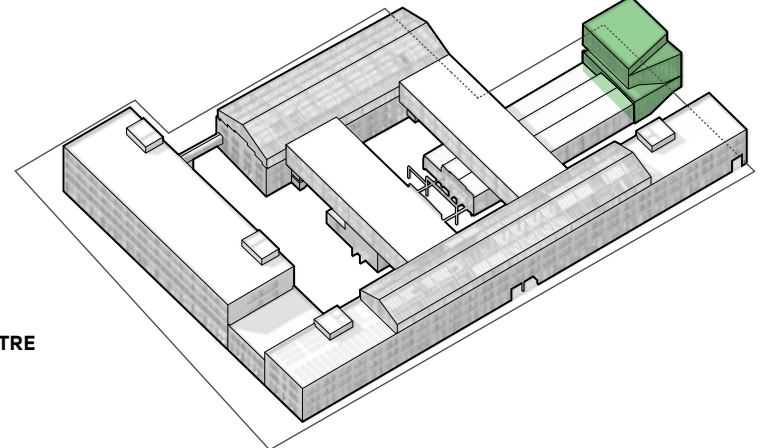

TRANSPORT+ZONING

**TRANSPORT
LOGISTICS**

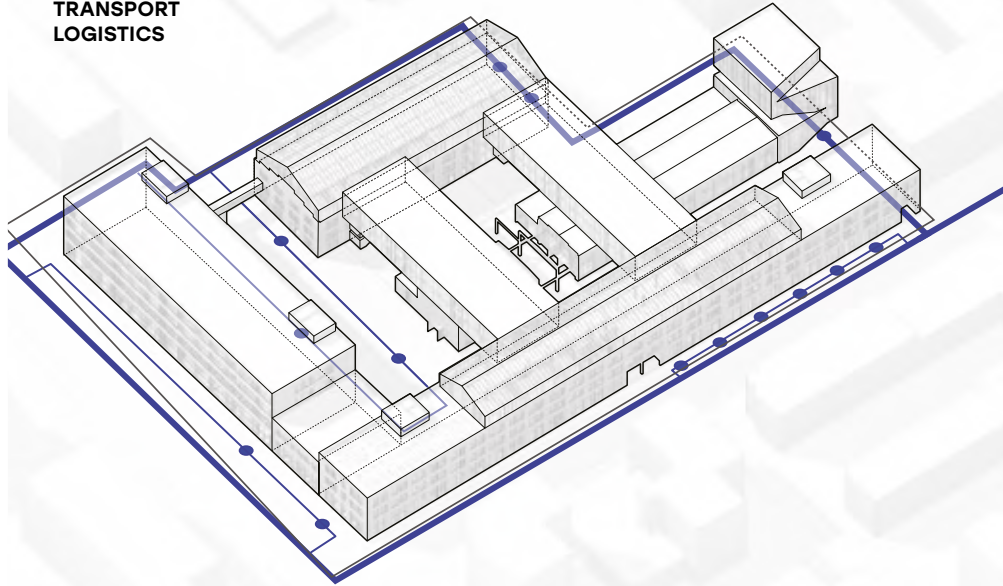

PEDESTRIANS
(internal paths through the building)

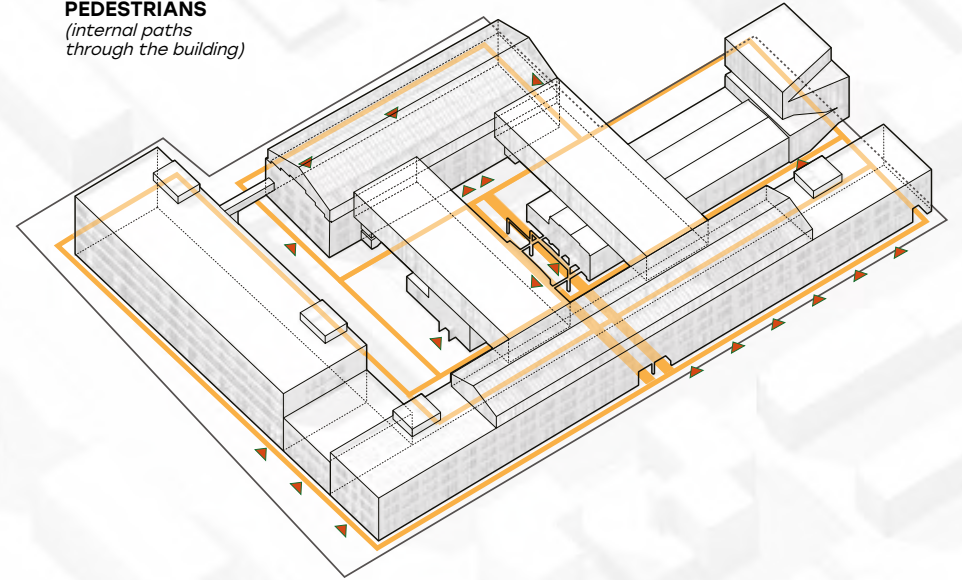

**GREEN ZONES
AND SQUARES**

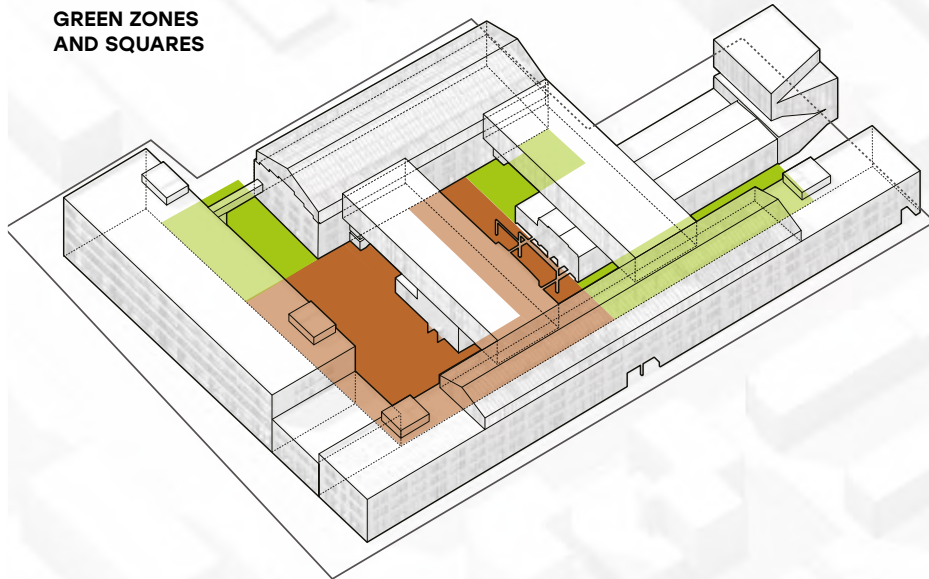

**ROOFS
EXPLOITATION**

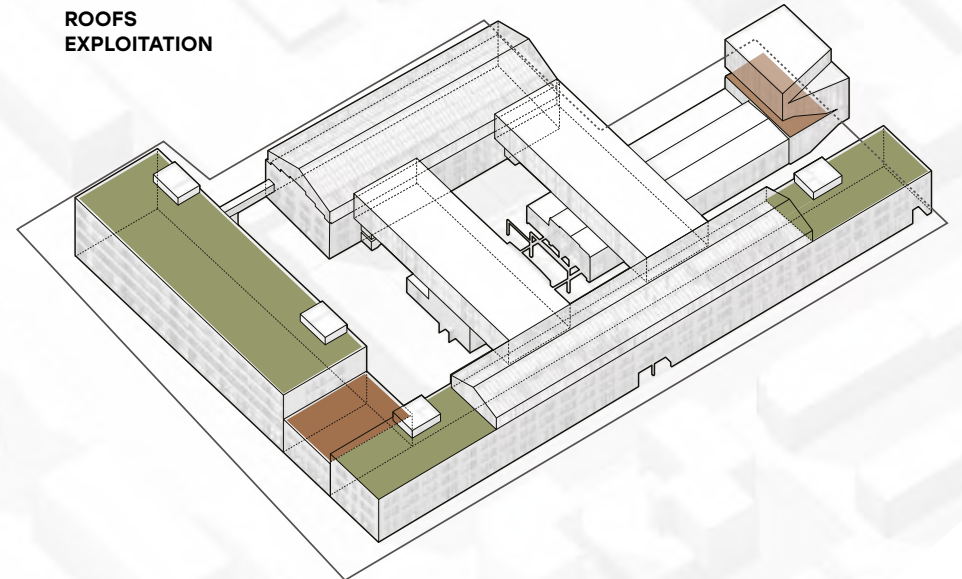

1 LEVEL

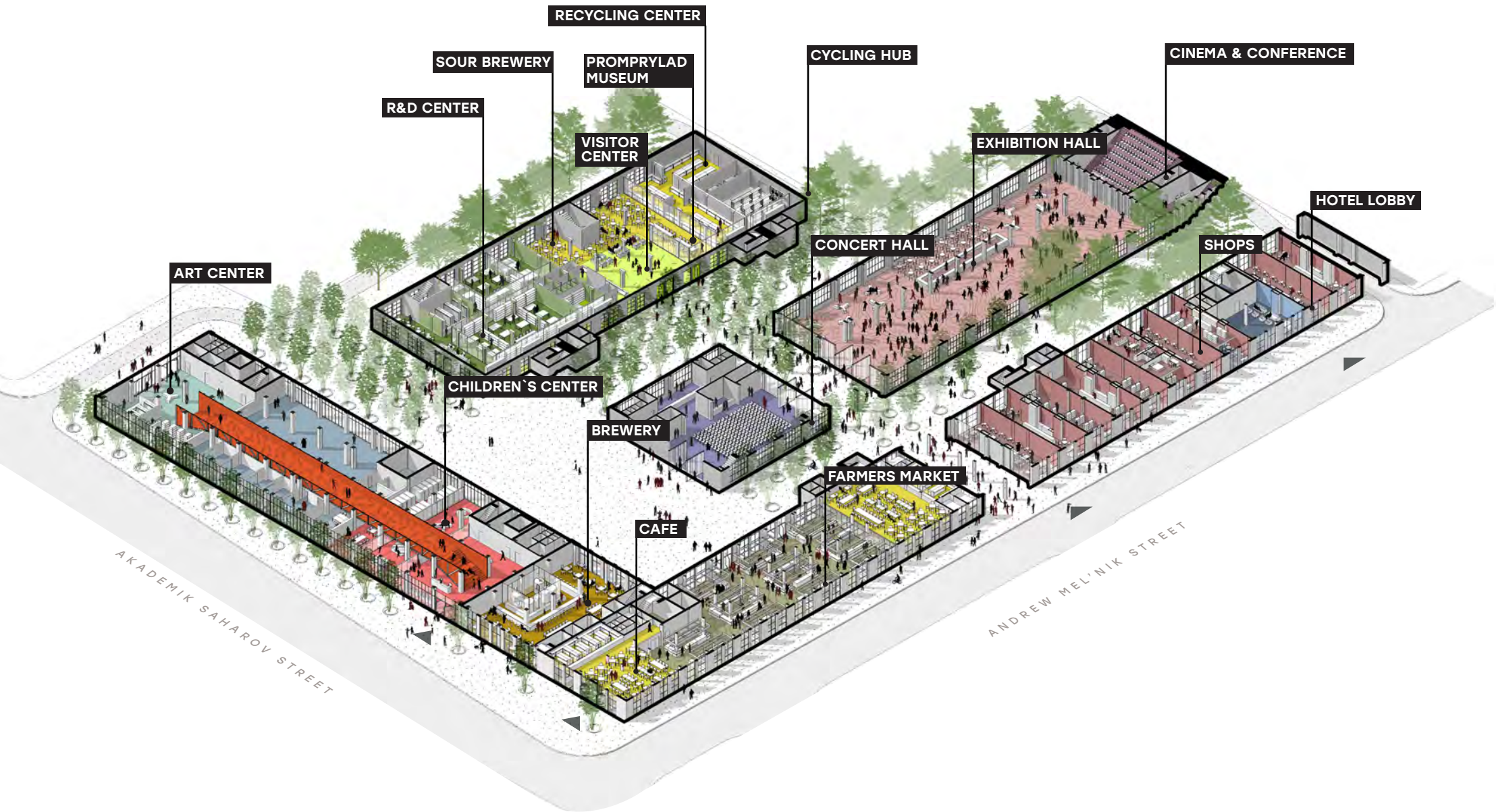

2 LEVEL

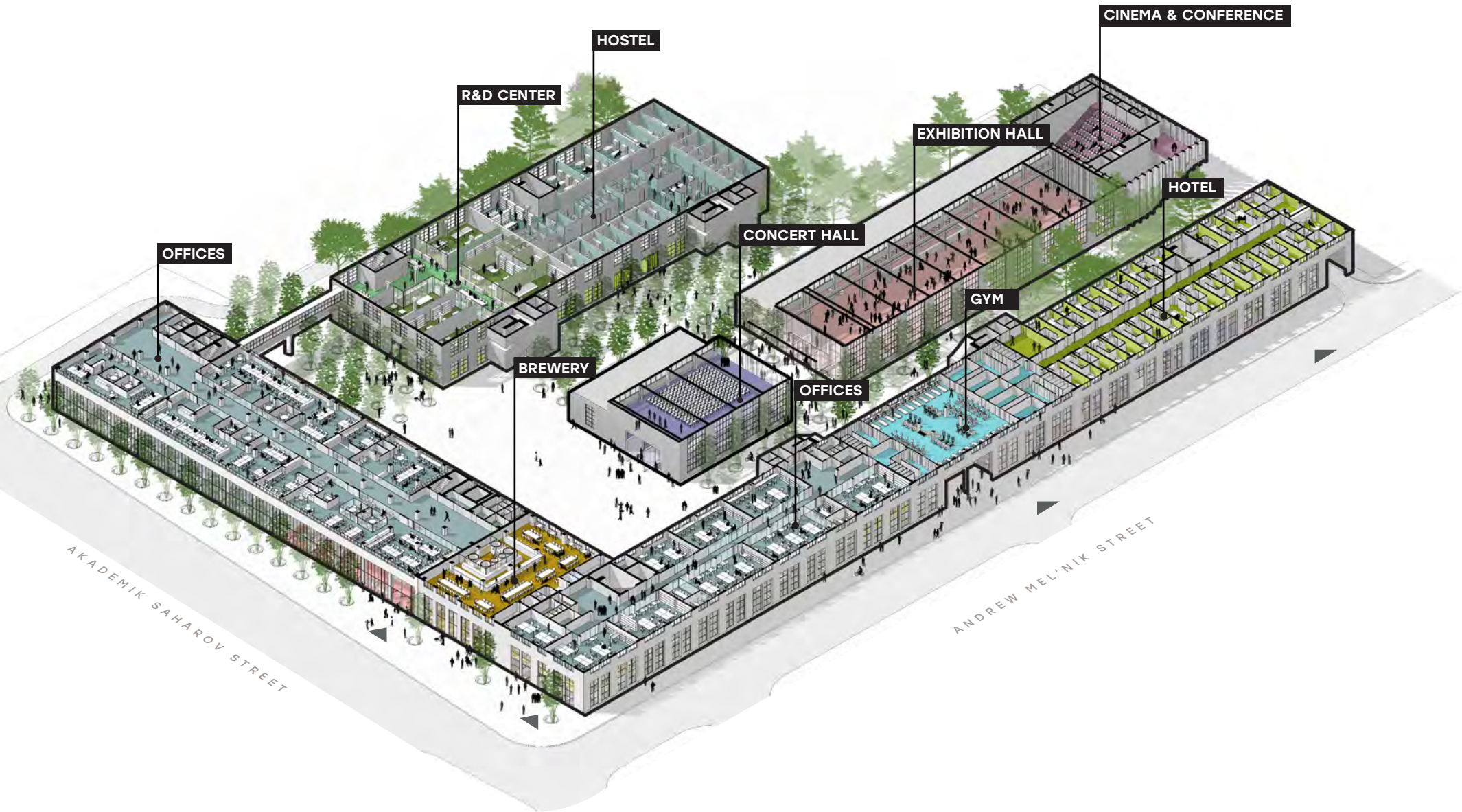

3 LEVEL

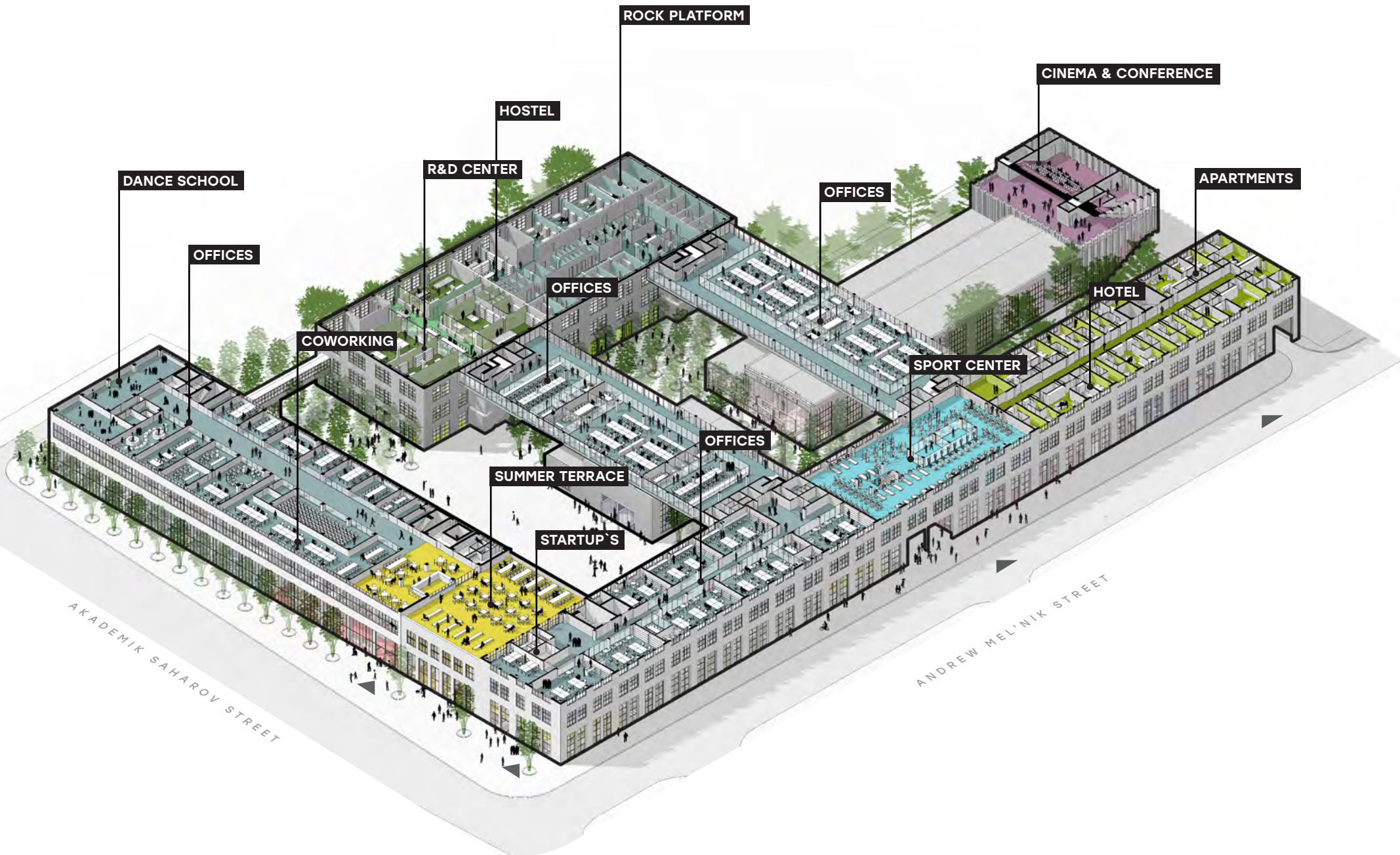

4 LEVEL

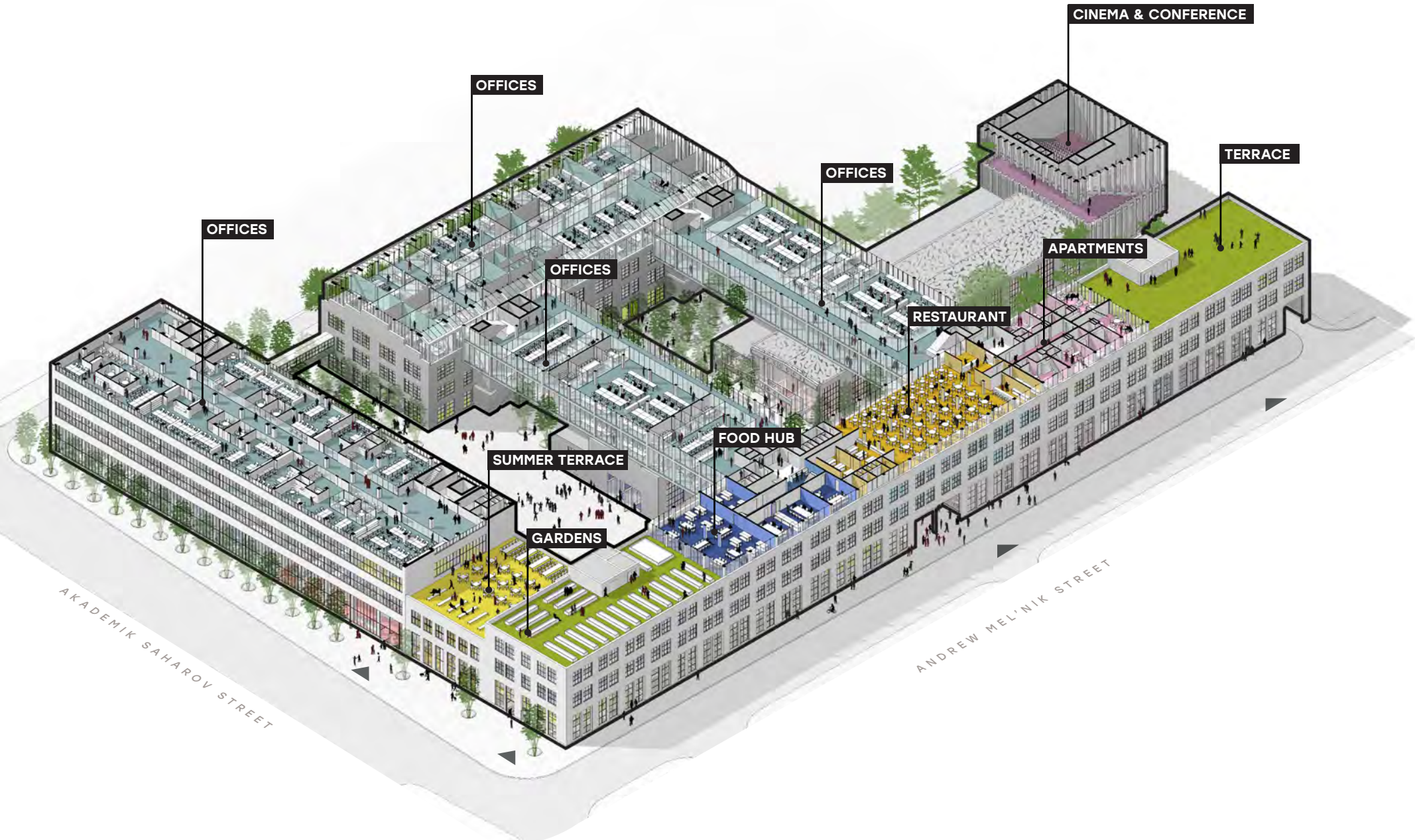

5 LEVEL

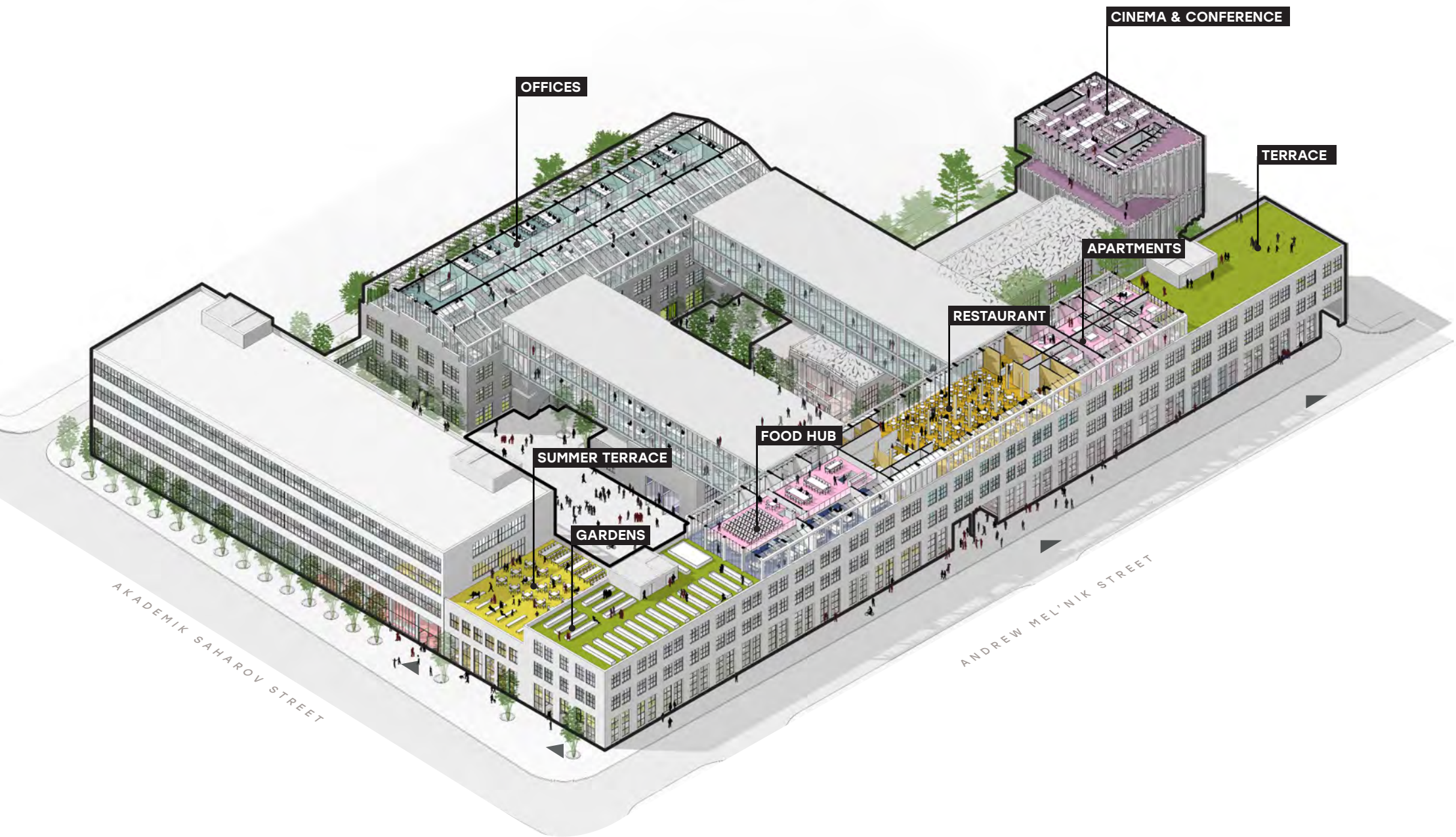





























BE A PART
OF CHANGES.
INVEST IN
PROMPRYLAD.
RENOVATION



promprylad.in.ua
investment@promprylad.in.ua
fb.com/promprylad.renovation